

LED Panel Light 10W

DATASHEET



POWERED BY

≈



INDEX

Product Bases.....	1
Product Picture.....	2
Technology Parameters.....	3
PSU Parameter.....	4
Product Drawing & Power Supply Connection.....	5
Installation.....	6
Packaging.....	7
Application.....	8

1- Product Bases

LED Panel 10 W Powered By  **LG Innotek**

Contains Floppy PCB with 50 Pcs Of LED Light Source 2835 LG Innotek

Made In Korea each Chip produces 110 LM/W With total Lumen 1100 LM

3mm PS Light guide Sheet out case of aluminum.

LED PSU based on flicker free, 0.95 PF and No over heat type

2 - Product Pictures



3-Technology Parameter

Spectrum Of Light:

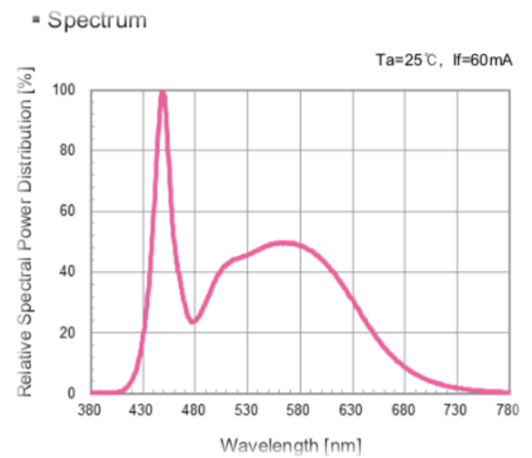

Model:	LED Panel 10W	Type:	Indoor Lighting
Product Name:	Daylight 10W	LED Type	LG Innotek
Application:	Office / Commercial	LED P/N	EGY-I-10W-101
Input Voltage	AC 100-277 V - 50/60 Hz		
Panel Light Input Voltage	DC 36 - 72 V		
Color Temperature available	4000K - 4500K / 5700K - 6500K		
Total Power (W)	10		
Total Flux (Lm)	>1100		
Efficacy (Lm/W)	110		
CRI	>80		
Beam Angle	120°		
Power Factor	0,80		
IP	IP65		
Operating Temperature	-20 °C to +50 °C		
Storage Temperature	-20 °C to +60 °C		
Life	30.000 Hours		

5. Electro - Optical Characteristics

(Ta=25°C)

If (mA)	Vf (V)	Power (W)	Φ_v (lm)	lm/W
50	2.99	0.150	21.5	143
60 (Typ.)	3.05	0.183	25.1	137
70	3.10	0.217	28.5	132
80	3.14	0.251	31.7	126
90	3.19	0.287	35.0	122

※ Φ_v values are for representative references only.

4 - SMPS Technology Parameter And Connection

Constant Current Source for LED driver



Features

- **High efficiency**
- **Compact size 1.40cm**
- **AC184-264V wide input voltage range**
- **Constant current output**
- **Isolated Input-Output**
- **High PF (PF 0.95)**
- **36~72V wide constant current operation range**
- **Low output ripple current & Voltage**
- **Built-in Output Short Protection**
- **Flicker free IC integrated**

5 - Installation

EMBEDDED TYPE

Steps:

- Taked of the false ceiling panel, put in the panel from diagonal.
- Fix the panel at the right place.

7- Packaging

Color Cartoon Box as first Page shown contains

1 LED Driv

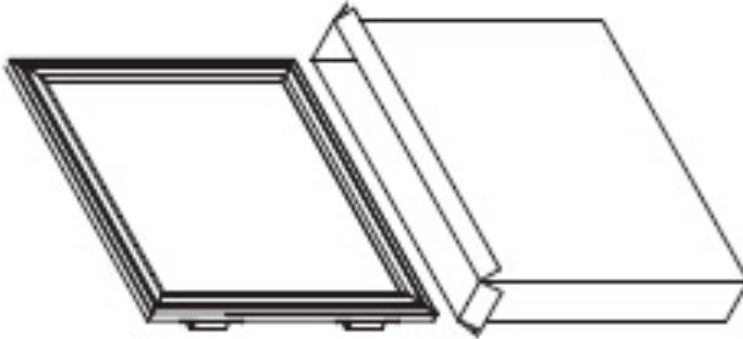

8 - Applications

- Office
- Shop
- Hotel
- Hospital
- work & waiting area
- Schools
- Elevators
- Bank
- Mall
- entrance

Datasheet is subject to change without notice last up date at Nov. 2020.